

# *Alpine* STRUCTURES

Restructure  
your backyard!



1.800.359.7522



Built On-Site &  
Pre-Built Structures





**Not all buildings are created equal.**

It all started one winter many years ago, in a small shop where our first storage barns were built. By the end of the year, our founder, Mose Miller, realized the need for storage buildings, and in 1981 Alpine Structures was born. As we continue to grow, Alpine Structures remains dedicated to providing high-quality products with excellent customer service. Our success is credited first and foremost to God who has blessed us abundantly with wonderful employees and loyal customers.

*Javan Miller, owner*



The Difference..... 4  
 Door System..... 5  
 Strongback Nailer ..... 6

Floor Models ..... 7  
 Structure Comparison ..... 8-9

**Alpine Structures ..... 10-29**

Bigger Buildings, Flexible Options



**Ez-fit Shed ..... 30-33**

Small Sheds With Big Features



**2000 Series ..... 34-41**

Our Most Economical Structures



**Large Structures ..... 42-49**

Cabins, Garages & Loft Barns



Site Prep ..... 50  
 ProStruct Flooring..... 51  
 Siding ..... 52-53  
 Roof Options..... 54

Window & Door Options..... 55  
 Paint & Stain Colors..... 56-57  
 Accessories ..... 58  
 Delivery..... 59



# quality from the inside out

Aluminum Dripedge...page 4

Metal Truss Plates...page 4

Shingle or Metal Roof...page 54

Primed Trim...page 4

Paint or Stain Colors...page 56-57

Strongback Nailer...page 6

2x4" Framing 16" O.C.

Premium Grade Lumber

4x4" Treated Runners

Choice of three Floor Models...page 7

Siding Options...pages 51-53

Triple-layer door system...page 5





discover the

# Alpine difference

THE DIFFERENCE

## Aluminum Dripedge



Added protection against rain, snow, and ice.

## Smartside Soffit and Frieze Board



Standard on Skyview, Cove, and Frontier. Optional on all other styles.

## Primed Trim



Standard on all buildings except barnsiding. Decay resistant, primed trim that is ready to face the outdoors.

## Metal Truss Plates



Provides superior strength versus wooden gussets.

## Double 2x8" top-plate



On Alpine Barnstyles, the rafter is located on outer edge of 2x8" top-plate. Increases wall strength and provides more loft storage.



**warranty**

We've been here since 1981 and we're committed to continue giving you complete satisfaction.



# the triple-layer door system

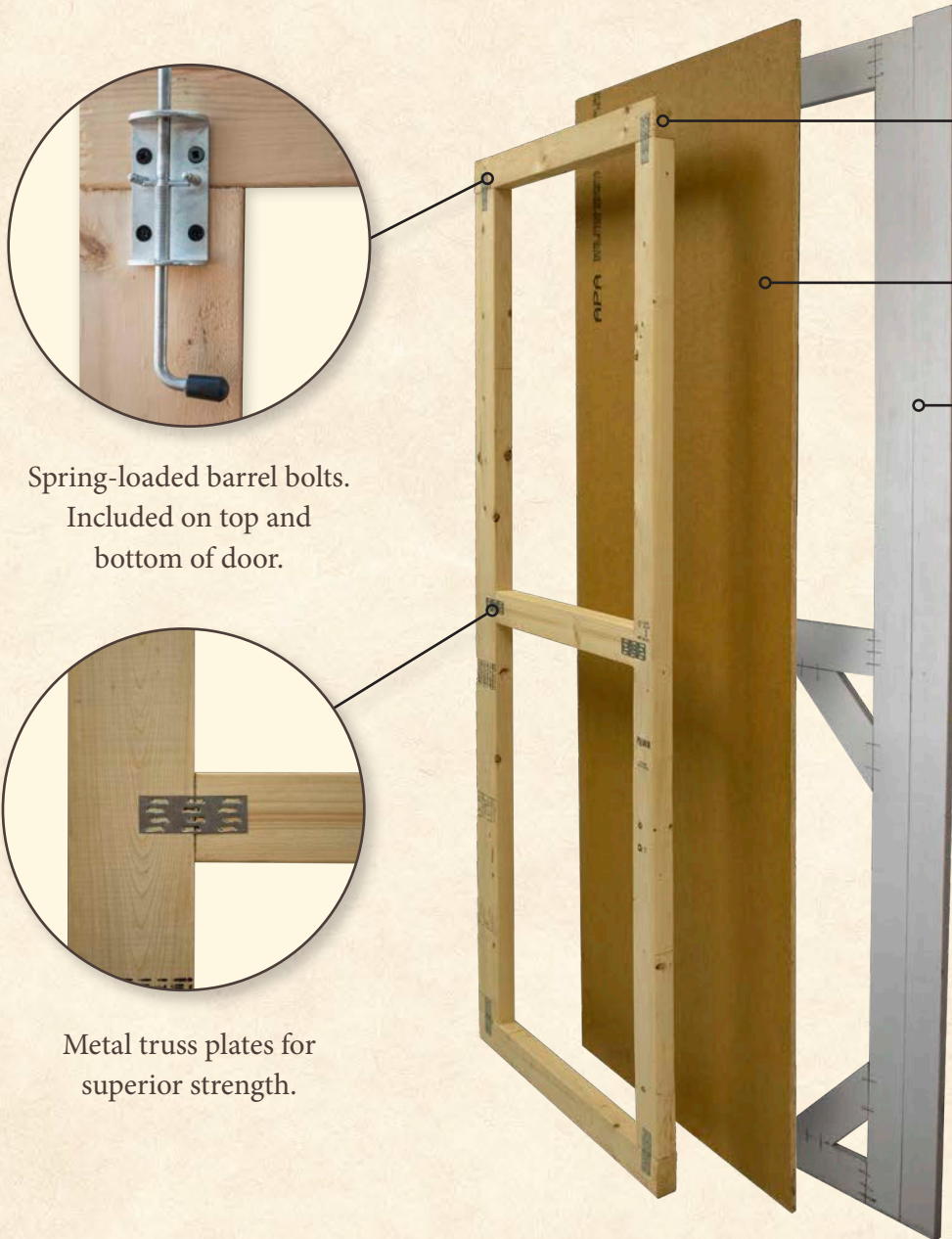

Spring-loaded barrel bolts.  
Included on top and bottom of door.

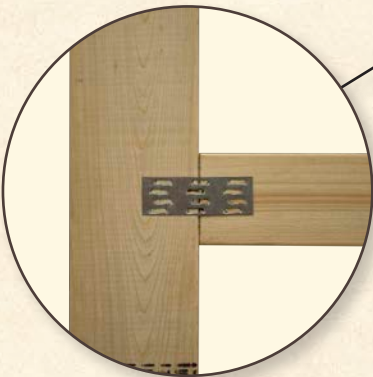

Metal truss plates for superior strength.

**Layer #1** – Our 2x3" Door frame is built with premium grade lumber and fastened with a metal truss plate for superior strength.

**Layer #2** – LP Smartside Siding that resists warping and cracking, and defies termite damage.

**Layer #3** – Decay resistant primed trim that is ready to face the outdoors.



6" Heavy-duty T-hinges with bushings.  
*Standard on Alpine & 2000 Series.*



12" Decorative T-hinges with bushings.  
*Standard on EZ-Fit Sheds.*



# Alpine strongback nailer

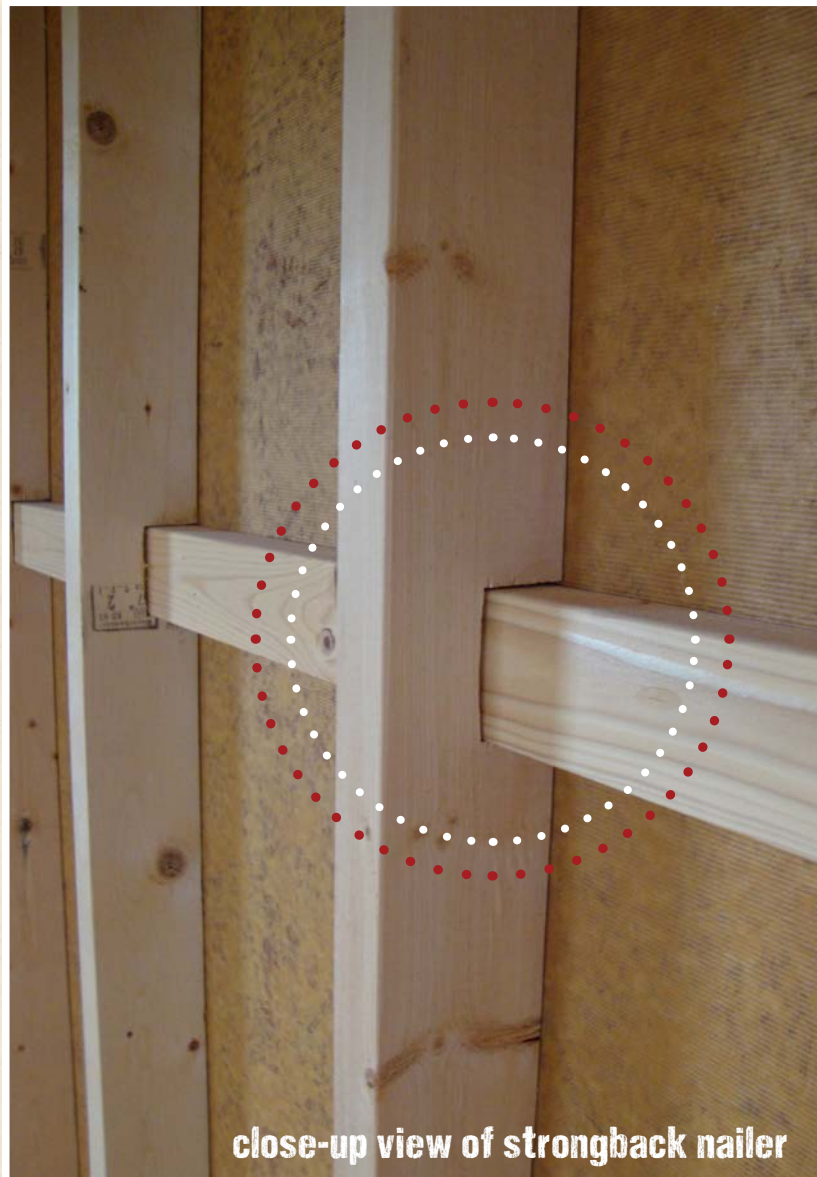

- A STRONGER WALL
- A STRAIGHTER WALL
- INCREASED NAILING SURFACE
- STANDARD ON ALL HIGH SIDEWALLS

.....

Using computerized components saws, each individual wall stud is cut with a specialized notch. We then install our 2x3" Strongback Nailer, creating a *straighter, stronger wall*, and providing *increased nailing surface* for our siding panels.





# floor models

## Why are the floor joists flat vs. on edge?

**Structural Integrity** – Flat joists mean more holding power by face-nailing floor joists to 4x4" runners vs. toe-nailing.

**Larger support area** – Actual distance between floor joists is only 12½"!

**Ease of use** – Enjoy a minimal step up into your building with this user friendly design.

### 2000 Series



**Floor:**

½" CDX Plywood-16" O.C. floor joists  
4x4" treated skids

**Walls:** 24" O.C. wall studs

┆ 24" + 24" ┆

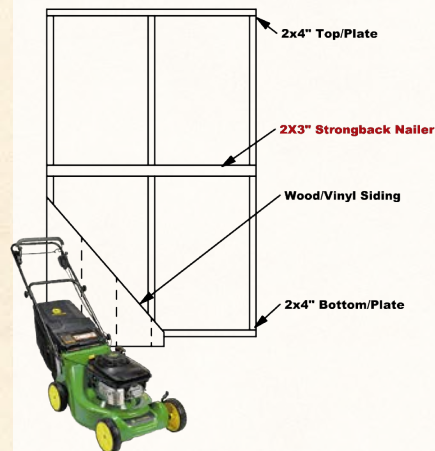

### Standard Model



**Floor:**

¾" CDX Plywood-16" O.C. floor joists  
4x4" treated skids

**Walls:** 24" O.C. wall studs

┆ 24" + 24" ┆

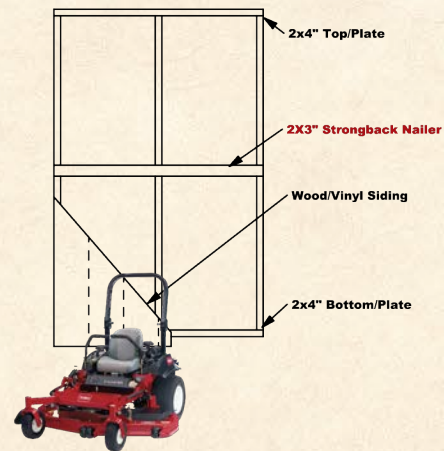

### Deluxe Model



**Floor:**

¾" ProStruct Flooring  
16" O.C. treated floor joists  
4x4" treated skids

**Walls:** 16" O.C. wall studs

┆ 16" + 16" + 16" ┆

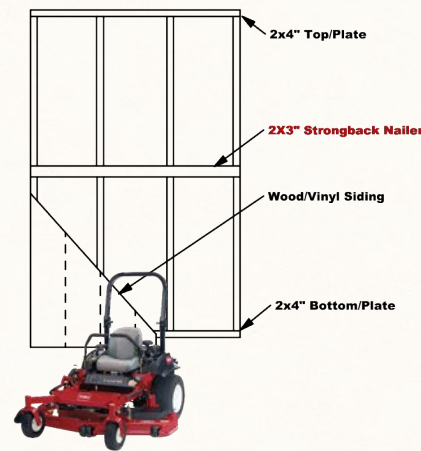

### Supreme Model

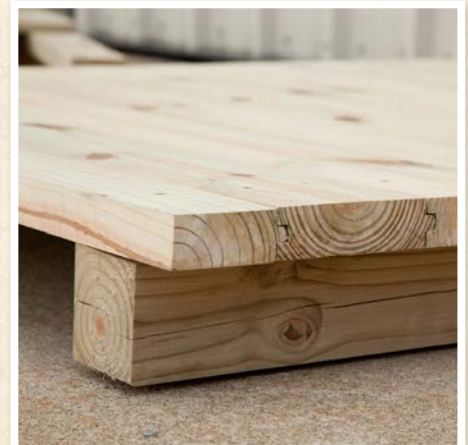

**Floor:**

2x6" Treated Tongue & Groove  
4x4" treated skids

**Walls:** 16" O.C. wall studs

┆ 16" + 16" + 16" ┆

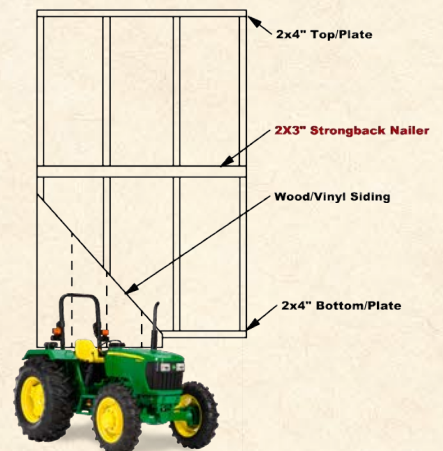

see page 51



# Alpine Structures

Our signature series — the Alpine Structures are bigger buildings, with flexible options. Building sizes start at 8x8' all the way to 16x32' and include special features like a 12" overhang on gable ends and air vents. Careful consideration should be taken when choosing the flooring, the Alpine Structures are available in standard, deluxe and supreme models, for more information see page 7.



Gable 12" O.H. **10**

6'6" Sidewalls  
1-24x36" Aluminum window  
Bar shutters  
52" Double doors  
4/12 Pitch roof  
2x4" Single top-plate  
Sizes: 8x8' – 16x32'



Barnstyle 4' **12**

4' Sidewalls  
52" Double doors  
2x8" Double top-plate  
Storage loft B\*\*  
Sizes: 8x8' – 14x24'



Barnstyle 6'6" **14**

6'6" Sidewalls  
52" Double doors  
2x8" Double top-plate  
Storage loft B\*\*  
Sizes: 8x8' – 16x32'



Barnstyle 4' O.H. **16**

6'6" Sidewalls  
52" Double doors  
2x8" Double top-plate  
Storage loft B\*\*  
Sizes: 10x12' – 16x32'



A-Frame 4' **18**

6'6" Sidewalls  
1-24x36" Aluminum window  
Bar shutters  
52" Double doors  
12/12 Pitch roof  
2x4" Single top-plate  
Storage loft B\*\*  
Sizes: 10x14' – 16x32'



Cottage **20**

6'6" Sidewalls  
1-24x36" Aluminum window  
Bar shutters  
52" Double doors  
30" Single door  
6/12 Pitch roof  
2x4" Single top-plate  
Sizes: 8x12' – 16x32'



Skyview **22**

6'6" Sidewalls  
2-24x36" Aluminum windows  
Bar shutters  
52" Double doors  
30" Single door  
8/12 Pitch roof  
2x4" Single top-plate  
Storage loft A\*  
Sizes: 8x12' – 16x32'



Cove **24**

6'6" Sidewalls  
2-24x36" Aluminum windows  
Bar shutters  
52" Double doors  
30" Single door  
6/12 Pitch roof  
2x4" Double top-plate  
Storage loft A\*  
Sizes: 8x12' – 16x32'



Frontier **26**

6'6" Sidewalls  
1-18x27", 1-24x36" alum. windows  
Bar Shutters  
52" Double doors  
30" Single door  
12/12 Pitch roof  
2x4" Single top-plate  
Storage loft A\*  
Sizes: 10x14' – 16x32'



Gable 42" **28**

6'6" Sidewalls  
1-24x36" Aluminum window  
Bar Shutters  
52" Double doors  
2x4" Single top-plate  
Sizes: 8x8' – 12x24'



Quaker **29**

6'6" Sidewalls  
1-24x36" Aluminum window  
Bar shutters  
52" Double doors  
2x4" Single top-plate  
Sizes: 8x8' – 12x24'

A\* = 4' loft in buildings up to 10' long, 2-4' lofts in buildings over 10' long.  
B\*\* = 2' loft in 8' wide buildings, 4' loft in 10' wides, 2-4' lofts in 12', 14', and 16' wides.

see page 7 for  
flooring options!





# EZ-Fit Sheds

Small Sheds With Big Features  
Available with standard, deluxe, or supreme floors

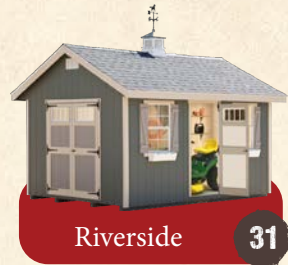

Riverside **31**



Homestead **32**



Heritage **33**

6'6" Sidewalls  
2 Windows, size varies per shed  
"Z" Shutters  
60" Double doors  
Decorative hinges  
6/12 Pitch roof  
6" Fascia  
2x4" Double top-plate  
Storage loft A\*  
Sizes: 8x8' - 12x24'

# 2000 Series

Our Most Economical Structures  
Available with 2000, standard, deluxe, or supreme floors



2000 Series 4' **34**

4' Sidewalls  
52" Double doors  
2x4" Single top-plate  
Sizes: 8x8' - 12x24'



2000 Series 6'6" **36**

6'6" Sidewalls  
52" Double doors  
2x4" Single top-plate  
Sizes: 8x10' - 12x24'



2000 Series Gable **38**

6'6" Sidewalls  
52" Double doors  
6/12 Pitch roof  
2x4" Single top-plate  
Sizes: 8x10' - 12x24'



2000 Series Garage **40**

6'6" Sidewalls  
1-24x36" Aluminum window  
8x6'6" Garage door  
36" Single door  
2x4" Single top-plate  
1-4' Loft  
Sizes: 12x16' - 12x28'



# Large Structures

Cabins, Garages & Loft Barns  
See page 50 for foundation options.



Barnstyle Cabin **42**

8' Sidewalls  
36" 9-lite entrance door  
2x8" Double top-plate  
Full loft w/steps  
Sizes: 16x20' - 16x32'



A-Frame Cabin **44**

8' Sidewalls  
36" 9-lite entrance door  
12/12 Pitch roof  
2x4" Double top-plate  
Full loft w/steps  
Sizes: 16x20' - 24x40'



Garage **46**

8' Sidewalls  
36" 9-lite entrance door  
4/12 Pitch roof  
2x4" Double top-plate  
Sizes: 20x20' - 30x48'



Loft Barns **48**

8' Sidewalls  
36" 9-lite entrance door  
2x8" Double top-plate  
Full loft w/steps  
Sizes: 20x20' - 24x40'

see page 50 for site prep details!

Restructure your backyard



# Alpine Gable

## WITH 12" OVERHANG

### STANDARD FEATURES

**FLOOR MODELS** see page 7  
Available in Standard, Deluxe or Supreme

**SIDEWALL HEIGHT**  
6'6" sidewalls (7'1" inside headroom)  
7' and 8' sidewalls optional

**ROOF**  
4 pitch roof  
Aluminum dripedge

**CONSTRUCTION**  
Strongback Nailer  
Primed Smartside Siding  
2x4" wall framing  
2x4" single top-plate  
4" fascia trim  
Air vents

**DOORS**  
52" double doors with USA made lockset

**WINDOWS**  
1 - 24x36" window with bar shutters

### ELITE PACKAGE INCLUDES

7' sidewalls  
6 pitch roof

**LOFTS**  
4' loft building up to 10' long  
2-4' loft in buildings over 10' long

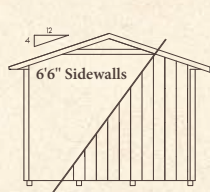

Standard  
6'6" Sidewalls - 4 Pitch - No Loft

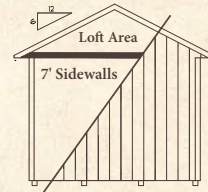

Elite Package  
7' Sidewalls - 6 Pitch - Loft

### BUILDING SIZES

WIDTH	DEPTH										STD. HEIGHT	ELITE HEIGHT
	8'	10'	12'	14'	16'	20'	24'	28'	32'			
8'	•	•	•								8' 8"	10'2"
10'		•	•	•	•	•					9'	10'8"
12'			•	•	•	•	•				9' 4"	11'2"
14'				•	•	•	•	•			9' 8"	11'8"
16'					•	•	•	•			10"	12'2"

ALSO AVAILABLE WITH 18" OVERHANG  
(18" o.h. in front and 6" o.h. in back)

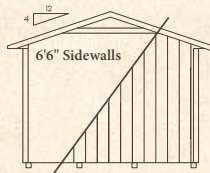

12" Overhang

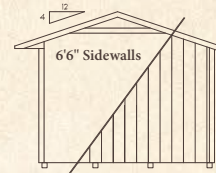

18" Overhang



10x20' Elite Gable with options



14x20' with elite package, vinyl siding, and metal roof



10x16' Elite Gable with transom windows and metal roof



8x12' Gable



Alpine

# Gable

with 12"  
overhang



**10x14' Alpine Gable**  
options shown:  
elite package  
dimensional shingles  
30x36" window w/shutters & flowerbox  
24x36" window w/shutters & flowerbox  
painted dark grey w/white trim, black shutters

Here's what  
I'm thinking...

"Easy pricing,  
lots of options,  
excellent customer  
service, and a great  
delivery."

Emily from  
Pittsburgh, PA  
May 2021



# Alpine Barnstyle

## WITH 4' HIGH SIDEWALLS

### STANDARD FEATURES

#### FLOOR MODELS see page 7

Available in Standard, Deluxe or Supreme

#### SIDEWALL HEIGHT

4' sidewalls

#### ROOF

Aluminum dripedge

#### CONSTRUCTION

Primed Smartside Siding

2x4" wall framing

2x8" double top-plate

Air vents

#### LOFTS

see chart below

#### DOORS

52" double doors with USA made lockset

### POPULAR OPTIONS

Cupola

30 year dimensional shingles

Double door threshold

### BUILDING SIZES

WIDTH	DEPTH							STD. HEIGHT	LOFT(S)
	8'	10'	12'	14'	16'	20'	24'		
8'	•	•	•					8' 6"	2'
10'		•	•	•	•	•		9' 5"	4'
12'			•	•	•	•	•	9' 8"	two 4'
14'					•	•	•	10'	two 4'

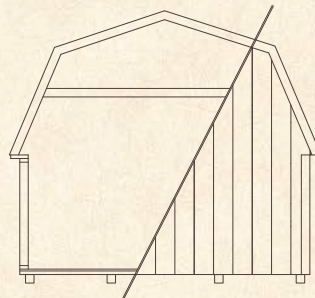

8x12' with vinyl siding



14x20' with transom windows, dim. shingles, and cupola



8x12' with treated ramp



10x16' with 72" doors and ramp



Alpine

# barnstyle

4' Sidewalls



Here's what  
I'm thinking...

"Very efficient  
and knowledgeable  
throughout the  
entire process!"

Greg from  
Bedford, OH  
July 2021

10x14' Alpine Barnstyle 4'  
options shown:  
60" doors, ramp  
painted red w/white trim



# Alpine Barnstyle

## WITH 6'6" HIGH SIDEWALLS

### STANDARD FEATURES

#### FLOOR MODELS see page 7

Available in Standard, Deluxe or Supreme

#### SIDEWALL HEIGHT

6'6" sidewalls

7' and 8' sidewalls optional

#### ROOF

Aluminum dripedge

#### CONSTRUCTION

Strongback Nailer

Primed Smartside Siding

2x4" wall framing

2x8" double top-plate

Air vents

#### LOFTS

see chart below

#### DOORS

52" double doors with USA made lockset

### POPULAR OPTIONS

Windows

30 year dimensional shingles

Cupola

Weathervane

### BUILDING SIZES

WIDTH	DEPTH									STD. HEIGHT	LOFT(S)
	8'	10'	12'	14'	16'	20'	24'	28'	32'		
8'	•	•	•							11' 2"	2'
10'		•	•	•	•	•				11' 10"	4'
12'			•	•	•	•	•			12' 2"	two 4'
14'					•	•	•	•	•	12' 5"	two 4'
16'						•	•	•	•	12' 8"	two 4'

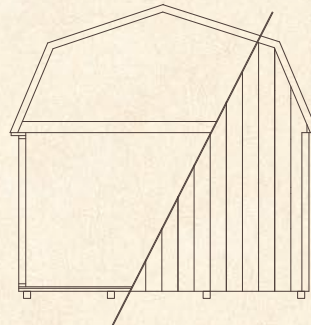

16x24' with garage door, 8' sidewalls, window, and dim. shingles



16x24' with 24x27" windows and shutters, loft door, 10' ridgelite and ridgevent, and custom ramp



14x28' with windows and shutters, transom windows, and custom ramps



Alpine

# barnstyle

6'6" Sidewalls

Here's what  
I'm thinking...

"The whole process  
was effortless.  
Very satisfied."

Chris from  
Aliquippa, PA  
May 2021

12x16' Alpine Barnstyle 6'6"  
options shown:  
treated ramp  
painted avocado green w/buckskin trim

Restructure your backyard



# Alpine Barnstyle

WITH 6'6" HIGH SIDEWALLS & 4' OVERHANG

## STANDARD FEATURES

### FLOOR MODELS see page 7

Available in Standard, Deluxe or Supreme

### SIDEWALL HEIGHT

6'6" sidewalls  
7' and 8' sidewalls optional

### ROOF

Aluminum dripedge  
4' self-supporting overhang  
6' overhang optional  
2x6" rafters

### CONSTRUCTION

Strongback Nailer  
Primed Smartside Siding  
2x4" wall framing  
2x8" double top-plate  
6" fascia trim  
Air vents

### LOFTS

see chart below

### DOORS

52" double doors with USA made lockset

## POPULAR OPTIONS

Treated deck  
Posts with "Y" braces  
Entrance door  
7' sidewalls  
Windows

## BUILDING SIZES

WIDTH	DEPTH							STD. HEIGHT	LOFT(S)
	12'	14'	16'	20'	24'	28'	32'		
10'	•	•	•	•				11' 10"	4'
12'	•	•	•	•	•			12' 2"	two 4'
14'			•	•	•	•	•	12' 5"	two 4'
16'				•	•	•	•	12' 8"	two 4'

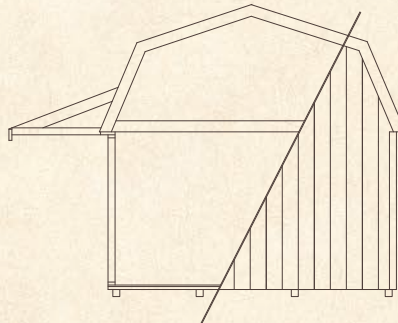

16x24' with 6' overhang and two windows



16x24' with garage door and two windows



10x20' with options



self-supporting overhang



Alpine

# barnstyle

4' overhang



**12x20" Barnstyle  
options shown:  
60" doors with transom window  
36" single door with transom window  
2 windows  
7' walls  
metal roof  
treated deck  
6" posts  
stained driftwood w/black trim**

Here's what  
I'm thinking...

"Excellent company  
to work with from  
start to finish!"

Robert from  
Elyria, OH  
August 2021



# Alpine A-Frame

## WITH 4' OVERHANG

### STANDARD FEATURES

**FLOOR MODELS** see page 7  
Available in Standard, Deluxe or Supreme

**SIDEWALL HEIGHT**  
6'6" sidewalls  
7' and 8' sidewalls optional

**ROOF**  
12 pitch roof  
Aluminum dripedge  
4' overhang

**CONSTRUCTION**  
Strongback Nailer  
Primed Smartside Siding  
2x4" wall framing  
2x4" single top-plate  
6" fascia trim  
Air vents  
4' treated deck with posts and "Y" braces

**LOFTS**  
2-4' lofts in buildings over 10' long

**DOORS**  
52" double doors with USA made lockset  
30" single door with USA made lockset

**WINDOWS**  
1-24x36" window with bar shutters

### POPULAR OPTIONS

7' sidewalls  
Insulated windows  
30 year dimensional shingles

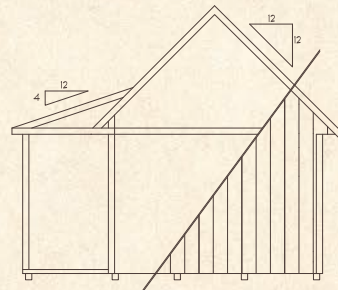

### BUILDING SIZES

WIDTH	DEPTH						HEIGHT	LOFTS
	14'	16'	20'	24'	28'	32'		
10'	•	•	•				13'	two-4'
12'		•	•	•			14'	two-4'
14'			•	•			15'	two-4'
16'			•	•	•	•	16'	two-4'



12x16' with 6' porch and numerous options



14x20' with 7' sidewalls, transom windows, and dim. shingles



12x14' with 7' walls, dim. shingles, and numerous options



Interior as an office



Alpine

# A-Frame

Here's what I'm thinking...

"The crew that came to build the shed were courteous, knowledgeable, and fast. Their workmanship was impeccable."

David from  
Canonsburg, PA  
August 2021

10x14' A-Frame  
options shown:  
7' sidewalls  
dimensional shingles  
24x36" window w/shutters  
painted avocado green w/buckskin trim



# Alpine Cottage

## STANDARD FEATURES

**FLOOR MODELS** see page 7  
Available in Standard, Deluxe or Supreme

**SIDEWALL HEIGHT**  
6'6" sidewalls (7' 1" inside headroom)  
7' and 8' sidewalls optional

**ROOF**  
6 pitch roof  
Aluminum dripedge

**CONSTRUCTION**  
Strongback Nailer  
Primed Smartside Siding  
2x4" wall framing  
2x4" single top-plate  
4" fascia trim  
Air vents  
4' treated deck with posts and "Y" braces

**DOORS**  
52" double doors with USA made lockset  
30" single door with USA made lockset

**WINDOWS**  
1 - 24x36" window with bar shutters

## BUILDING SIZES

WIDTH	DEPTH							STD. HEIGHT	ELITE HEIGHT
	10'	12'	14'	16'	20'	24'	28'		
8'		•						10' 5"	11' 1"
10'	•	•	•	•	•			10' 11"	11' 7"
12'		•	•	•	•	•		11' 5"	12' 1"
14'				•	•	•	•	12' 1"	12' 9"
16'					•	•	•	12' 5"	13' 3"

## ELITE PACKAGE INCLUDES

7' sidewalls  
6 pitch roof

**LOFTS**  
4' loft in building up to 10' long  
2-4' lofts in buildings over 10' long

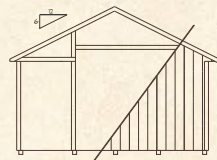

Standard  
6'6" Sidewalls - 4 Pitch - No Loft

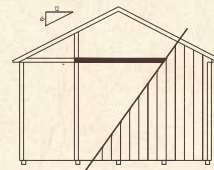

Elite Package  
7' Sidewalls - 6 Pitch - Loft



12x16' Elite Cottage with 8/12 pitch roof and many options



16x24' with vinyl siding, 8' sidewalls, dim. shingles, steel door, and windows



16x24' Elite Cottage, roof awning, cupola, and many options



10x20' Elite Cottage, 6' porch, and many options

*Note:* Gable style buildings with 12", 18" and 42" overhangs do not include a porch floor.

Cottage style buildings include a porch floor.



Alpine

# Cottage



**10x16" Cottage  
options shown:  
elite package  
double 30x36" window w/shutters  
60" double doors w/transom windows  
decorative hinges  
metal roof  
6" fascia  
painted beige w/clay trim**

Here's what  
I'm thinking...

"The staff was  
knowledgeable, easy  
to work with, and  
very thorough."

Michael from  
Pittsburgh, PA  
August 2020



# Alpine Skyview

## STANDARD FEATURES

**FLOOR MODELS** see page 7  
Available in Standard, Deluxe or Supreme

**SIDEWALL HEIGHT**  
6'6" sidewalls  
7' and 8' sidewalls optional

**ROOF**  
8 pitch roof (9 pitch roof on 8x12' Skyview)  
8' dormer with transom windows  
Enclosed soffits  
Frieze board  
Aluminum dripedge  
30 year dimensional shingles

**CONSTRUCTION**  
Strongback Nailer  
Primed Smartside Siding  
2x4" wall framing  
2x4" single top plate  
4" fascia trim  
Air vents

**LOFTS**  
2-4' lofts in buildings over 10' long

**DOORS**  
52" double doors with USA made lockset  
30" single door with USA made lockset

**WINDOWS**  
2 - 24x36" windows with 1 set bar shutters

## POPULAR OPTIONS

Transom windows  
Metal roof  
Flowerboxes

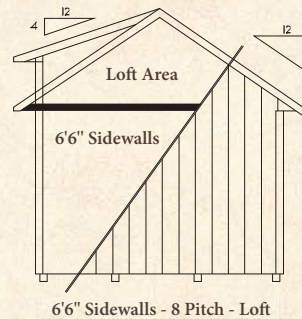

## BUILDING SIZES

	WIDTH							STD. HEIGHT
	12'	14'	16'	20'	24'	28'	32'	
8'	•							10' 8"
10'		•	•	•				10' 11"
12'			•	•	•			11' 7"
14'				•	•	•	•	12' 3"
16'					•	•	•	12' 11"



16x32' with 8' walls and numerous options



10x16' with lap siding and transom windows



10x12' with transom windows and ramp



Alpine

# SKYVIEW



## Here's what I'm thinking...

"Assembly of my structure was very professional and fast. Extremely happy with my overall experience."

Cheri from Broadview Heights, OH

**10x16' Skyview**  
**options shown:**  
**transom windows**  
**1 - extra 24x36" window**  
**stained driftwood w/ black trim**



# Alpine Cove

## STANDARD FEATURES

**FLOOR MODELS** see page 7  
Available in Standard, Deluxe or Supreme

**SIDEWALL HEIGHT**  
6'6" sidewalls  
7' and 8' sidewalls optional

**ROOF**  
6 pitch roof  
Aluminum dripedge  
Enclosed soffits  
Frieze board  
30 year dimensional shingles

**CONSTRUCTION**  
Strongback Nailer  
Primed Smartside Siding  
2x4" wall framing  
2x4" double top-plate  
4" fascia trim  
Air vents

**LOFTS**  
4' loft in buildings up to 10' long  
2-4' lofts in buildings over 10' over

**DOORS**  
52" double doors with USA made lockset  
30" single door with USA made lockset

**WINDOWS**  
2-24x36" windows with bar shutters

## POPULAR OPTIONS

Transom windows  
Decorative hinges

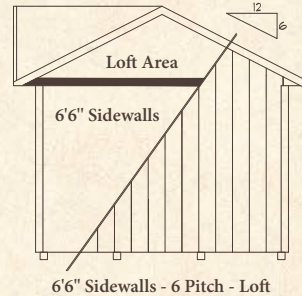

## BUILDING SIZES

	WIDTH							STD. HEIGHT
	12'	14'	16'	20'	24'	28'	32'	
8'	•							9' 9"
10'		•	•	•				10' 3"
12'			•	•	•			10' 9"
14'				•	•	•	•	11' 3"
16'					•	•	•	10' 9"



10x14' Alpine Cove with 60" doors and ramp



16x32' with metal roof and options



10x14' with transom windows and ramp



The Cove interior



Alpine

COVE



Here's what I'm thinking...

"Good product, friendly service, excellent builders."

Harry from West Aliquippa, PA  
October 2021

10x16' Cove  
options shown:  
60" double doors  
transom windows  
flowerboxes  
painted dark grey w/white trim

Restructure your backyard



# Alpine Frontier

## STANDARD FEATURES

**FLOOR MODELS** see page 7  
Available in Standard, Deluxe or Supreme

**SIDEWALL HEIGHT**  
6'6" sidewalls  
7' and 8' sidewalls optional

**ROOF**  
12 pitch roof  
Roof apron on front gable  
Enclosed soffits  
Frieze board  
Aluminum dripedge

**CONSTRUCTION**  
Strongback Nailer  
Primed Smartside Siding  
2x4" wall framing  
2x4" single top-plate  
6" fascia trim  
Air vents

**LOFTS**  
4' loft in buildings up to 10' long  
2-4' lofts in buildings over 10' long

**DOORS**  
52" double doors with USA made lockset  
30" single door with USA made lockset

**WINDOWS**  
1-24x36" window with bar shutters  
1-18x27" window with bar shutters in front gable

## POPULAR OPTIONS

Loft railing  
Captain's ladder to loft  
Garage Door  
7' sidewalls  
Shake siding

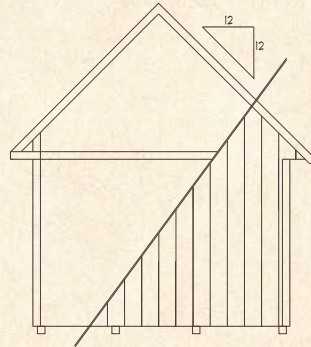

## BUILDING SIZES

	WIDTH						STD. HEIGHT
	14'	16'	20'	24'	28'	32'	
10'	•	•	•				13'
12'		•	•	•			14'
14'			•	•	•		15'
16'				•	•	•	16'



12x20' with options



10x14' with extra windows, transom windows, and ramps



12x16' with an extra window and ramp



Alpine

# Frontier

Here's what  
I'm thinking...

"The entire process  
was so easy and  
tailored to my needs!  
You guys are great!"

Jay from  
Gahanna, OH

12x16' Frontier  
options shown:  
carriage house garage door  
7" sidewalls  
vinyl siding  
shake siding on gable  
dimensional shingles  
vinyl siding: alpine clay w/white trim

Restructure your backyard



# Alpine Gable

## WITH 42" OVERHANG

### STANDARD FEATURES

**FLOOR MODELS** see page 7  
Available in Standard, Deluxe or Supreme

**SIDEWALL HEIGHT**  
6'6" sidewalls (7' 1" inside headroom)  
7' and 8' sidewalls optional

**ROOF**  
4 pitch roof  
Aluminum dripedge  
42" overhang

**CONSTRUCTION**  
Strongback Nailer  
Primed Smartside Siding  
2x4" wall framing  
2x4" single top-plate  
Air vents

**DOORS**  
52" double doors with USA made lockset

**WINDOWS**  
1- 24x36" window with bar shutters

### ELITE PACKAGE INCLUDES

7' sidewalls  
6 pitch roof

**LOFTS**  
4' loft in buildings up to 10' long  
2-4' lofts in buildings over 10' long

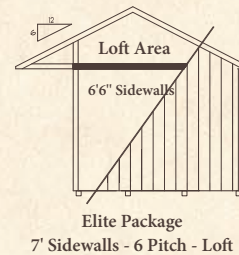
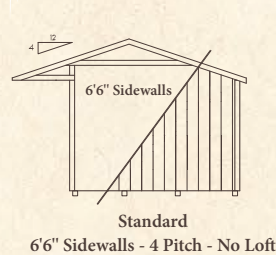

### BUILDING SIZES

WIDTH	DEPTH						STD. HEIGHT	ELITE HEIGHT
	8'	10'	12'	14'	16'	20'		
8'	•	•	•				9'	10' 8"
10'		•	•	•	•	•	9' 4"	11' 2"
12'			•	•	•	•	9' 8"	11' 8"





# Alpine Quaker

## STANDARD FEATURES

**FLOOR MODELS** see page 7  
Available in Standard, Deluxe or Supreme

**SIDEWALL HEIGHT**  
6'6" sidewalls (7' 1" inside headroom)  
7' and 8' sidewalls optional

**ROOF**  
Aluminum dripedge

**CONSTRUCTION**  
Strongback Nailer  
Primed Smartside Siding  
2x4" wall framing  
2x4" single top-plate  
4" fascia trim  
Air vents

**DOORS**  
52" double doors with USA made lockset

**WINDOWS**  
1- 24x36" window with bar shutters

## ELITE PACKAGE INCLUDES

7' sidewalls

**LOFTS**  
4' loft in buildings up to 10' long  
2-4' lofts in buildings over 10' long



**10x12' Quaker**  
options shown:  
painted clay w/red trim



10x14' Quaker



10x12' diamonds top and bottom

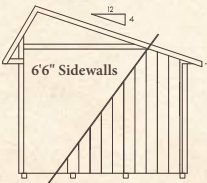

Standard  
6'6" Sidewalls - No Loft

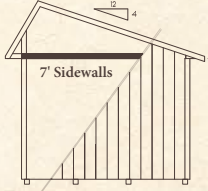

Elite Package  
7' Sidewalls - Loft

## BUILDING SIZES

WIDTH	DEPTH						STD. HEIGHT	ELITE HEIGHT
	8'	10'	12'	14'	16'	20'		
8'	•	•	•				9'8"	10'4"
10'		•	•	•	•		10'2"	10'10"
12'			•	•	•	•	10'5"	11'1"

Restructure your backyard



# Ez-Fit Sheds

Small sheds with big features

## STANDARD FEATURES

**FLOOR MODELS** see page 7  
Available in Standard, Deluxe or Supreme

**SIDEWALL HEIGHT**  
6'6" sidewalls  
7' and 8' sidewalls optional

**ROOF**  
6 pitch roof  
25 year shingles  
Aluminum dripedge

**CONSTRUCTION**  
Strongback Nailer  
Primed Smartside Siding  
2x4" double top-plate  
6" fascia trim  
Air vents

**LOFTS**  
4' loft in buildings up to 10' long  
2-4' lofts in buildings over 10' long

**DOORS**  
60" double doors with USA made lockset  
12" Decorative hinges

**WINDOWS**  
"Z" Shutters

## THREE BUILDING STYLES

**RIVERSIDE**  
60" double doors  
30" single door  
2-24x36" windows



**HERITAGE**  
60" double doors  
1-24x36" window  
1-30x36" window



**HOMESTEAD**  
60" double doors  
1- Double 30x36" window



## EZ-FIT SHED SIZES

WIDTH	DEPTH						HEIGHT
	8'	10'	12'	14'	16'	20'	
8'	•	•	•				9' 9"
10'		•	•	•	•	•	10' 3"
12'					•	•	10' 9"

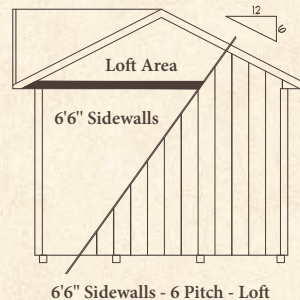

10x14' Riverside transom windows, cupola, and many options



10x12' Heritage transom windows, flowerboxes, and dim. shingles



10x12' Riverside transom windows, flowerboxes, and cupola



10x14' Heritage with 7' walls, transom windows, and metal roof



EZ-Fit

# Riverside

10x14' Riverside  
**options shown:**  
dimensional shingles  
transom windows  
vinyl flowerboxes  
16" cupola  
weathervane  
treated ramp  
painted avocado green w/beige trim

Here's what  
I'm thinking...

"I liked the flexibility  
with customizing  
my project, speed  
of construction."

Tyler from  
Pittsburgh, PA  
Dec 2020



EZ-Fit

# homestead

Here's what  
I'm thinking....

"They genuinely  
cared about us.  
They listened to  
our dilemma.  
They promised,  
they delivered."

Al & Connie from  
Elyria, OH

See page 30 for features,  
options, and building sizes!

10x12' Homestead  
options shown:  
dimensional shingles  
transom windows  
vinyl flowerboxes  
16" cupola  
horse weathervane  
painted red w/white trim



See page 30 for features,  
options, and building sizes!

EZ-Fit  
**Heritage**



Here's what  
I'm thinking...

"Friendly,  
informative,  
good quality,  
good value."

Brent from  
Worthington, OH  
May 2021

10x12' Heritage  
**options shown:**  
dimensional shingles  
transom windows  
vinyl flowerboxes  
decorative flowerbox holders  
16" cupola  
eagle weathervane  
painted beige w/clay



# 2000 Series

## WITH 4' HIGH SIDEWALLS

Our 2000 Series sheds offer plenty of storage at an affordable price. Includes 1/2" C.D.X. flooring with optional heavier floors available.

### STANDARD FEATURES

**FLOOR MODELS** see page 7  
 1/2" C.D.X. plywood floor  
 Available in 2000 Series, Standard, Deluxe or Supreme

**SIDEWALL HEIGHT**  
 4' sidewalls

**ROOF**  
 Aluminum dripedge  
 6" roof overhang front and back

**CONSTRUCTION**  
 Primed Smartside Siding  
 2x4" wall framing  
 2x4" single top-plate  
 Wall framing 24" o.c.

**DOORS**  
 52" double doors with USA made lockset

### BUILDING SIZES

WIDTH	DEPTH							HEIGHT
	8'	10'	12'	14'	16'	20'	24'	
8'	•	•	•					7' 10"
10'		•	•	•	•	•		8' 3"
12' *					•	•	•	8' 7"

\*12' wide 2000 Series floor width: 11' 6"

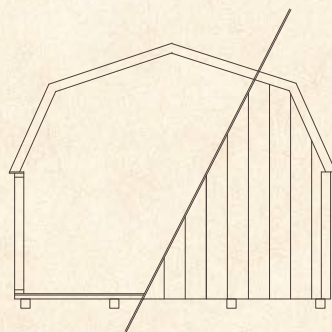

### COMPARE TO

### Alpine Barnstyle

#### WITH 4' HIGH SIDEWALLS

**2000 Series Does Not Include:**  
 2x8" double top plate  
 Lofts  
 Air vents  
 12" roof overhang front and back  
 3/4" ProStruct or 2x6" T.G. flooring

**2000 Series Includes:**  
 2x4" single top plate  
 6" roof overhang front and back  
 1/2" C.D.X. plywood floor  
 Less headroom than Alpine Barnstyle 4'  
 12' wide 2000 Series floor width: 11' 6"



8x12' 2000 Series



8x12' 2000 Series



10x12' with vents, 60" doors and ramp



2000

Series

4' Sidewalls

Here's what  
I'm thinking...

"I liked the attention  
to detail throughout  
the entire process."

Scott & Anne  
from Canton, OH  
June 2021

**10x16' 2000 Series 4'**  
**options shown:**  
**standard features**  
**painted buckskin w/white trim**

Restructure your backyard

35



# 2000 Series

## WITH 6'6" HIGH SIDEWALLS

Our 2000 Series sheds offer plenty of storage at an affordable price. Includes 1/2" C.D.X. flooring with optional heavier floors available.

### STANDARD FEATURES

**FLOOR MODELS** see page 7  
 1/2" C.D.X. plywood floor  
 Available in 2000 Series, Standard, Deluxe or Supreme

**SIDEWALL HEIGHT**  
 6'6" sidewalls

**ROOF**  
 Aluminum dripedge  
 6" roof overhang front and back

**CONSTRUCTION**  
 Strongback Nailer  
 Primed Smartside Siding  
 2x4" wall framing  
 2x4" single top-plate  
 Wall framing 24" o.c.

**DOORS**  
 52" double doors with USA made lockset

### COMPARE TO

#### *Alpine Barnstyle* WITH 6'6" HIGH SIDEWALLS

**2000 Series Does Not Include:**  
 2x8" double top plate  
 Lofts  
 Air vents  
 12" roof overhang front and back  
 3/4" ProStruct or 2x6" T.G. flooring

**2000 Series Includes:**  
 2x4" single top plate  
 6" roof overhang front and back  
 1/2" C.D.X. plywood floor  
 Less headroom than Alpine Barnstyle 6'6"  
 12' wide 2000 Series floor width: 11' 6"



12x16' with window and ramp



10x20' with numerous options



10x12 with ramp, vents, and ridgeline

### BUILDING SIZES

WIDTH	DEPTH							HEIGHT
	8'	10'	12'	14'	16'	20'	24'	
8'	•	•	•					10' 5"
10'		•	•	•	•	•		10' 8"
12' *			•		•	•	•	10' 11"

\*12' wide 2000 Series floor width: 11' 6"

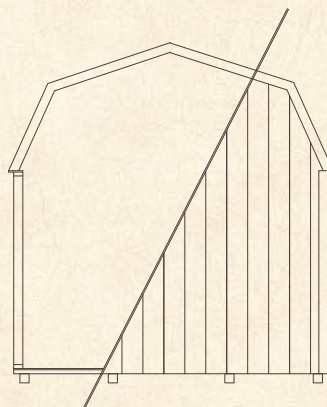



2000

Series

6'6" Sidewalls



Here's what I'm thinking...

"Very good quality and friendly staff. Builders were excellent - hard workers."

Mark from Akron, OH

**10x16' 2000 Series 6'6"**  
**options shown:**  
72" doors  
vents, ridge light  
ramp  
painted clay w/white trim



# 2000 Series Gable

Our 2000 Series sheds offer plenty of storage at an affordable price. Includes 1/2" C.D.X. flooring with optional heavier floors available.

## STANDARD FEATURES

### FLOOR MODELS see page 7

1/2" C.D.X. plywood floor  
Available in 2000 Series, Standard, Deluxe or Supreme

### SIDEWALL HEIGHT

6'6" sidewalls

### ROOF

Aluminum dripedge  
6" roof overhang front and back  
6 pitch roof

### CONSTRUCTION

Strongback Nailer  
Primed Smartside Siding  
2x4" wall framing  
2x4" single top-plate  
4" fascia trim  
Wall framing 24" o.c.

### DOORS

52" double doors with USA made lockset

## BUILDING SIZES

WIDTH	DEPTH							HEIGHT
	8'	10'	12'	14'	16'	20'	24'	
8'		•	•					9' 1"
10'		•	•	•	•	•		9' 7"
12' *					•	•	•	10'

\*12' wide 2000 Series floor width: 11' 6"

## COMPARE TO

### Alpine Gable WITH 12" OVERHANG

#### 2000 Series Gable Does Not Include:

12" roof overhang on all sides  
lofts  
air vents  
3/4" ProStruct or 2x6" T.G. flooring

#### 2000 Series Includes:

2x4" single top plate  
6" roof overhang front and back  
1/2" C.D.X. plywood floor  
12' wide 2000 Series floor width: 11' 6"

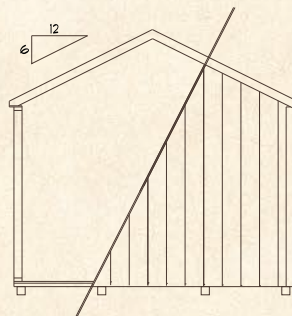

8x12' 2000 Series Gable with driftwood stain

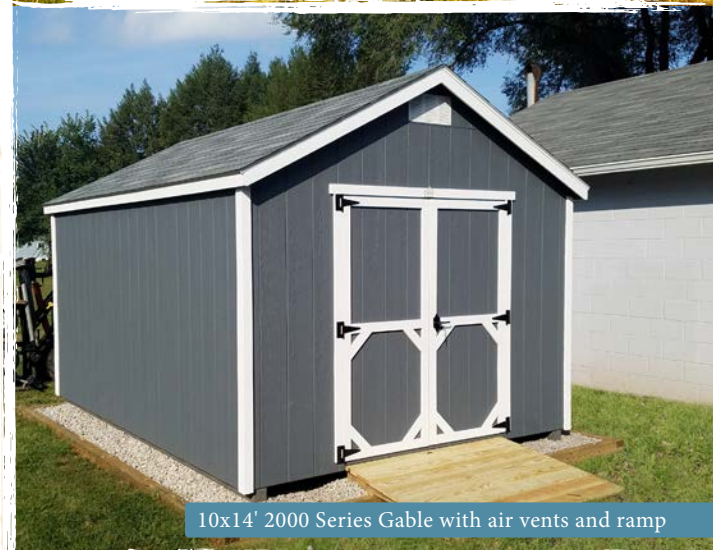

10x14' 2000 Series Gable with air vents and ramp



12x20' 2000 Series Gable with options



2000

Series

Gable



Here's what  
I'm thinking...

"The entire process  
was easy, they kept  
you informed of  
everything. Customer  
service is excellent!"

Denman from  
Beaver, Falls PA  
Dec 2020

10x12' 2000 Series Gable  
options shown:  
60" doors, ramp,  
transom windows, vent  
painted buckskin w/white trim



# 2000 Series Garage

Our 2000 Series sheds offer plenty of storage at an affordable price.

## STANDARD FEATURES

### FLOOR MODELS SEE PAGE 7

Available in Deluxe or Supreme  
 2x4" treated floor joists 12" o.c.  
 3/4" ProStruct floor

### SIDEWALL HEIGHT

6'6" sidewalls – on barnstyle  
 7' sidewalls – on gable style

### ROOF

6 pitch roof – on gable style  
 6" roof overhang front and back  
 Aluminum dripedge

### CONSTRUCTION

Strongback Nailer  
 Primed Smartside Siding  
 2x4" wall framing  
 2x4" single top-plate

### LOFTS

4' loft in back of building

### DOORS

36" single door with USA made lockset  
 8'x6'6" non-insulated garage door  
 Metal garage door threshold

### WINDOWS

1-24x36" aluminum window

## TWO BUILDING STYLES

### GABLE STYLE

7' walls  
 6 pitch roof  
 10'9" height



### BARNSTYLE

6'6" walls  
 10'11" height

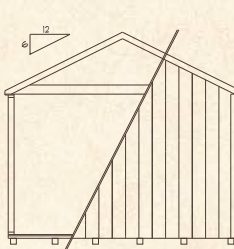

Gable Style Garage

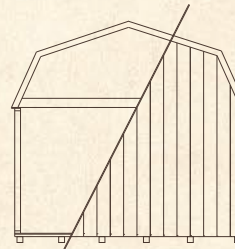

Original Barnstyle Garage

## BUILDING SIZES

WIDTH	DEPTH				HEIGHT BARN:	HEIGHT GABLE:
	16'	20'	24'	28'		
12'*	•	•	•	•	10' 11"	10' 9"

\*2000 Series Garage floor width: 11' 6"



12x20' with carriage house door, and more options



12x20' 2000 Series Garage – Gable Style



12x20' 2000 Series Garage



12x24' 2000 Series Garage, vents



2000  
**SERIES**  
Garage

Here's what  
I'm thinking...

"Communication  
before install and  
onsite build was  
thorough and made  
a great result."

Michael from  
Poland, OH  
November 2021

12x20' 2000 Series Garage  
options shown:  
standard features  
painted buckskin w/white trim



# Alpine Barnstyle Cabin

## WITH 6' OVERHANG

### STANDARD FEATURES

**FLOOR MODELS** see page 7  
see price list for flooring options

**SIDEWALL HEIGHT**  
8' sidewalls (7'1" first floor headroom)  
6' rafter (6'5" second floor headroom)

**ROOF**  
6' overhang  
2x6" rafters  
Aluminum dripedge  
30 year dimensional shingles

**CONSTRUCTION**  
Strongback Nailer  
Primed Smartside Siding  
Treated deck  
Posts with "Y" braces  
2x4" wall framing  
Air vents  
Synthetic felt paper  
Truss anchor screws

**LOFTS**  
Full loft with steps  
2x10" loft joists 16" o.c. below top plate

**DOORS**  
Entrance door with glass

### POPULAR OPTIONS

Vinyl insulated windows  
Ridgevent and vented soffit

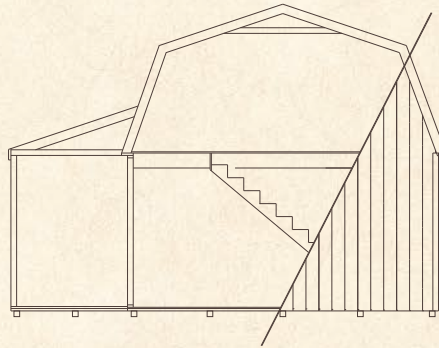

### BUILDING SIZES

WIDTH	DEPTH				HEIGHT
	20'	24'	28'	32'	
16'	•	•	•	•	16' 4"



16x24' with vinyl siding



standard feature - full loft with steps and railings



16x24' with metal roof and other options



16x24' with two 6' overhangs, post foundation, and other options



Alpine

# barnstyle

Cabin

Here's what  
I'm thinking...

"I loved the flexibility  
to customize my  
shed. We got just  
the look we wanted."

James from  
Berea, OH  
Sept 2021

**16x24' Barnstyle Cabin**  
options shown:  
30x36" windows  
22" cupola  
weathervane  
painted clay w/avocado green trim



# Alpine A-Frame Cabin

## WITH 6' OVERHANG

### STANDARD FEATURES

**FLOOR MODELS** see page 7  
see price list for flooring options

**SIDEWALL HEIGHT**  
8' sidewalls

**ROOF**  
12 pitch roof  
Aluminum dripedge  
6' overhang  
30 year dimensional shingles

**CONSTRUCTION**

Strongback Nailer	Wall studs 16" o.c.
Primed Smartside Siding	6" fascia trim
2x4" wall framing	Synthetic felt paper
2x4" double top-plate	Truss anchor screws
Air vents	

**DOORS**  
Entrance door with glass

**LOFTS**  
Full loft w/steps, landing, and railing  
Loft below top plate  
2x10" loft joists 16" o.c. 16' wide buildings  
14" floor trusses 24" o.c. 20' wide buildings  
16" floor trusses 24" o.c. 24' wide buildings

**DECKS**  
6' deck and "Y" posts are standard on 16' wide cabins  
  
6' deck and posts are optional on 20' and 24' wide cabins

### POPULAR OPTIONS

Vinyl insulated windows  
Ridgevent and vented soffit  
Additional doors

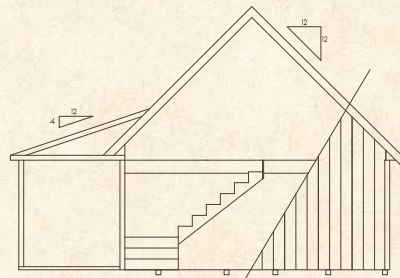

### BUILDING SIZES

WIDTH	DEPTH						HEIGHT
	20'	24'	28'	32'	36'	40'	
16'	•	•	•	•			17' 7"
20'		•	•	•	•	•	19' 9"
24'		•	•	•	•	•	21' 9"



20x28' with options



Full loft, standard feature. Interior finish/work by customer



16x20' with vinyl siding



24x36' with attached garage



Alpine

# Starframe

Cabin

Here's what  
I'm thinking...

"They were on time,  
friendly and gave  
good advice."

Starlette from  
Cleveland, OH  
September 2021

16x24' A-Frame Cabin  
options shown:  
30x36" window with shutters  
treated porch railing  
painted avocado green w/buckskin trim



# Alpine Garages

## STANDARD FEATURES

### FLOOR MODEL

Permanent foundation required  
- see page 50.

### SIDEWALL HEIGHT

8' sidewalls

### ROOF

4 pitch roof  
Aluminum dripedge  
OSB roof sheathing  
30 year dimensional shingles  
12" overhang on all sides

### CONSTRUCTION

Strongback Nailer  
Primed Smartside Siding  
2x4" wall framing  
2x4" double top-plate  
Wall studs 16" o.c.  
Air vents  
Synthetic felt paper  
Truss Anchor Screws

### DOORS

Entrance door with glass

## POPULAR OPTIONS

Vinyl insulated windows  
Ridgevent and vented soffit  
8-16' wide garage doors  
Vinyl siding  
Steeper roof pitch  
2x6" walls

## GARAGE DOOR COLORS

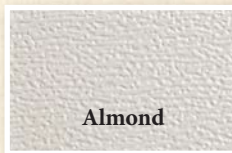

*Due to variables in the printing process, color samples may vary in color and sheen from the actual materials.*

## BUILDING SIZES

WIDTH	DEPTH						HEIGHT
	20'	24'	28'	32'	36'	40'	
20'	•	•	•	•	•	•	12'
24'		•	•	•	•	•	12' 10"

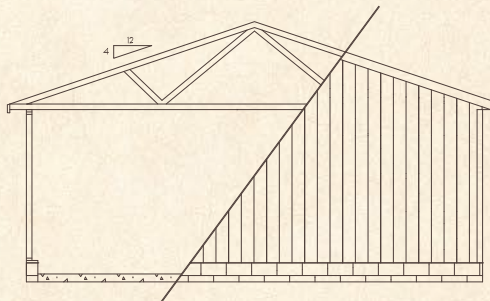



Alpine

# garages



**24x28' Garage  
options shown:  
2-9x7' garage doors  
45° garage door corners  
6 pitch roof  
cupola & weathervane  
gutters**

**Here's what  
I'm thinking...**

*"Everyone was easy to  
work with, answered all  
our questions in a kind  
and respectful manner.  
Great customer  
service."*

*Martin from  
Doylestown, OH  
September 2020*



# Alpine Loft Barns

## STANDARD FEATURES

### FLOOR MODELS

Permanent foundation required  
- see page 50.

### SIDEWALL HEIGHT

8' sidewalls

### ROOF

Aluminum dripedge  
2x6" roof trusses 24" o.c.  
OSB roof sheathing  
30 year dimensional shingles

### CONSTRUCTION

Strongback Nailer  
Primed Smartside Siding  
2x4" wall framing  
Wall studs 16" o.c.

Air vents  
Synthetic felt paper  
Steps and railings  
Truss anchor screws

### LOFTS

Full loft (see chart for headroom)  
Clearspan floor trusses for loft area

### DOORS

Entrance door with glass

## POPULAR OPTIONS

Vinyl insulated windows  
Ridgevent and vented soffit  
8' Overhang with posts  
Porch and railing  
8'-16' Wide Garage Doors  
2x6" Walls

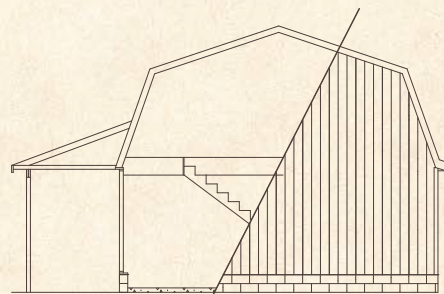
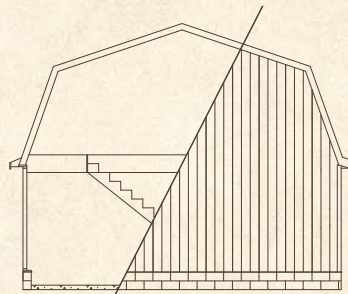

## BUILDING SIZES

WIDTH	DEPTH						BLDG. HEIGHT	LOFT HEIGHT
	20'	24'	28'	32'	36'	40'		
20'	•	•	•	•	•	•	18'	7' 10"
24'	•	•	•	•	•	•	18' 8"	8' 5"



24x32' Loft Barn with metal roof and options



24x32' Loft Barn



24x40' with 8' overhang



24x48' with 8' overhang



Alpine

# loft barns

**24x40' Loft Barn  
options shown:  
8' overhang  
posts with "Y" braces  
garage door, loft door  
windows, cupola  
painted red w/white trim**

**Here's what  
I'm thinking...**

*"The two young men  
that built my shed  
were great, nice,  
and worked hard."*

Bill from  
Chardon, OH  
October 2021





# Site Prep

Alpine Structures offers several of these site-prep options. Ask your salesman for availability in your area.

## SMALL STRUCTURES



level limestone base

1. Limestone base should be 12" larger than building on four sides.
2. Remove 3-4" of sod.
3. Fill back in with No. 8 or No. 57 limestone.
4. Make sure entire area of limestone is level.



INSTALLED BY ALPINE

patio block base

8"x16" x 2" thick concrete patio blocks are placed underneath each skid a maximum of 6' on center.



INSTALLED BY ALPINE

block/4x4" foundation

4x4"s are placed crossways underneath building. 4x4" supported with solid concrete blocks on low side and dug into ground (as needed) on high side.

great for smaller sheds!

## LARGE STRUCTURES



INSTALLED BY ALPINE

post and beam foundation

Pressure/treated posts with 2x8" stringers for sloped applications.



INSTALLED BY ALPINE

post and rim foundation

Pressure/treated posts 8' o.c. with 2x8" treated rim boards and 2x8" treated cap.



block foundation

Block foundation with frost protected footer and concrete floor.





## An Attractive, Durable Finish For Sheds

A flooring designed and warranted specifically for sheds, LP® ProStruct® Flooring with SmartFinish® features a durable overlay for a beautiful, professional-grade appearance. With no knots or voids, it's a welcome change from building with traditional plywood flooring. Plus, unlike plywood shed floors, LP® ProStruct® Flooring with SmartFinish® is treated with the LP® SmartGuard® process for longer-lasting performance in a variety of climates/weather.



FLOORING



## Features & Benefits

### A Shed Floor With Protection Against Decay & Damage

The shed floor you've been searching for is here, specially treated with SmartGuard® wood strand technology to resist fungal decay and termite damage.

.....

### An Easy Shed Floor Install

The LP® ProStruct® Flooring with SmartFinish® installs like conventional floor panels.

### Knot and Void Free

Durable overlay for a professional-grade appearance with no knots or voids so your shed floor is as durable as it is attractive.

.....

### Longer-Lasting Performance

SmartFinish® flooring has excellent resistance to warping, splitting and cupping.



# Siding Options

## LP SmartSide Siding

*Standard on all buildings*

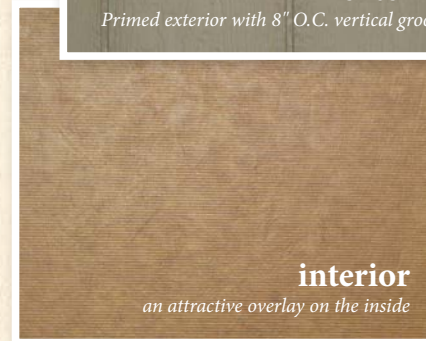

### A Natural Defense Against Nature

All LP® SmartSide® products are treated to the core through LP's proprietary SmartGuard® process. With four components of protection, the SmartGuard process adds strength and helps LP SmartSide products withstand impacts, freeze/thaw cycles, high humidity, fungal decay and more. SmartSide siding is backed by a 50 year prorated limited warranty.

**We're proud to offer SmartSide® standard on all of our buildings.**

#### Waxes

Special water-resistant waxes coat each strand or fiber of wood for enhanced durability in rainy, humid environments.



#### Resin-Saturated Overlay

Offering the final layer of protection against the elements, a resin-saturated overlay resists moisture intrusion while providing a durable base for quality paint adhesion and beauty.

#### Zinc Borate

Engineered wood products treated with zinc borate have been proven to effectively resist damage from termites and fungal decay for decades. Safe for children and pets, this naturally occurring additive provides long-lasting performance that preserves the beauty of LP SmartSide Trim and Siding.



#### Advanced Binders

LP SmartSide Trim and Siding provide incredible strength to resist impact damage thanks to their industrial grade binders and resins. You'll have the confidence of knowing that your siding can stand up to everyday airborne debris such as hail, sticks, or golf balls.



# LP Horizontal Lap Siding

## Standard features

- 50 year prorated, limited warranty
- Treated with a Zinc Borate application
- Resistant to fungal decay and termite damage
- Primed face



10x16' Elite Gable with options



10x14' Elite Gable

# Vinyl Siding

## Standard features

- Double 4" dutchlap siding
- OSB subsiding & sheathing
- 4' Ridgevent
- Available on all sizes & styles

## Options

- Flowerboxes
- Vinyl railing

## Base color includes

- Siding
- Corner Trim
- Soffit

## Trim color includes

- Door Trim
- Fascia



14x20' Elite Gable



10x14 Elite Gable



Vinyl sided buildings come standard with 60" wide Fiberglass slab doors with transom windows. 6 panel and 9 lite doors also available.



alpine white

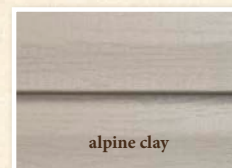

alpine clay

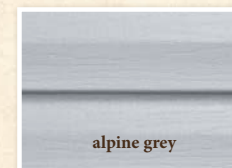

alpine grey

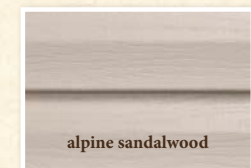

alpine sandalwood

Due to variables in the printing process, color samples may vary in color and sheen from the actual materials.



# Roof Options

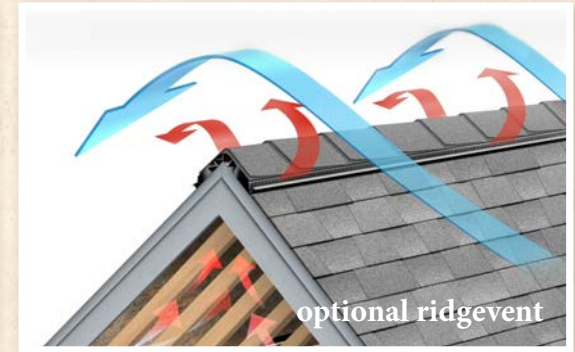

## STANDARD 3-TAB SHINGLES



## DIMENSIONAL SHINGLES

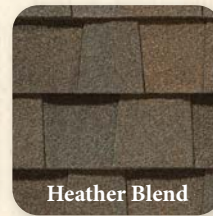
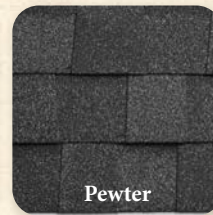

## METAL ROOF

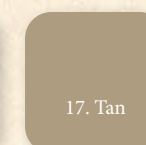
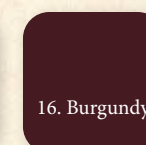
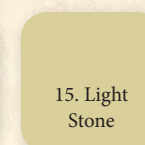
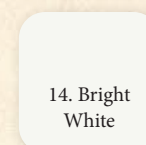
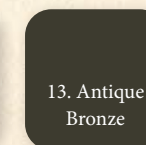
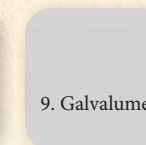
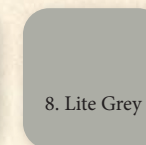
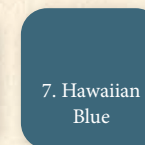
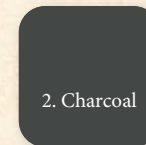



# Window & Door Options

Due to variables in the printing process, color samples may vary in color and sheen from the actual materials.

## VINYL SHUTTER & FLOWERBOX COLORS

- |          |          |
|----------|----------|
| 1. White | 4. Green |
| 2. Black | 5. Grey  |
| 3. Brown | 6. Clay  |



1. 2. 3. 4. 5. 6.

## WINDOWS SIZES & STYLES

- |                 |                  |
|-----------------|------------------|
| <i>Aluminum</i> | <i>Insulated</i> |
| 18x27"          | 24x36"           |
| 24x36"          | 36x40"           |
| 30x36"          |                  |

1. Window with trim
2. Wooden Bar Shutters
3. Wooden "Z" shutters and vinyl flowerbox
4. Vinyl Shutters



1. 2. 3. 4.

## DOORS

1. Plain Door
2. Diamond bottom (*standard*)
3. Decorative Hinges (*standard on EZ-Fit Series*)
4. Decorative Hinges w/Transom windows
5. Fiberglass w/transom windows
6. Entrance door w/glass
7. Entrance door 6 panel



1. 2. 3. 4. 5. 6. 7.



# Paint & Stain Options

## STANDARD PAINT & TRIM COLORS

Painting is included with prebuilt structures & optional for built onsite structures.



*Due to variables in the printing process, color samples may vary in color and sheen from the actual materials.*

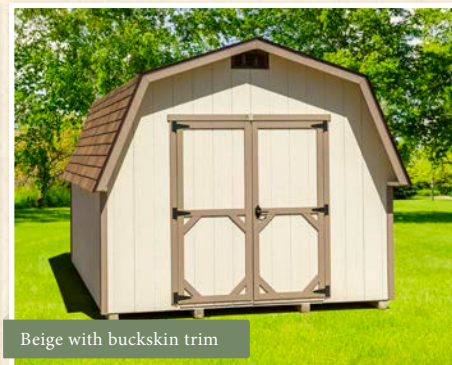





Driftwood Stain

Chestnut Brown with Buckskin Trim

## URETHANE STAINS

Enjoy the beauty of a semi-transparent stain coupled with the durability of Smartside siding. Also includes painted trim.



## POPULAR OPTIONS

Here's some of our favorite color schemes!



Accent



Accent

STAIN

*Due to variables in the printing process, color samples may vary in color and sheen from the actual materials.*



# Options & Accessories

## MISCELLANEOUS OPTIONS

1. Treated ramp 48", 60", or 72" width
2. Steps and railing
3. Steps with landing
4. 4' Treated deck
5. Shelving
6. Loft Ladder

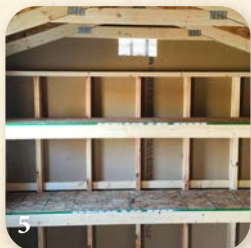

## CUPOLAS & WEATHERVANES

1. Cupolas: painted white, 16" or 22"
2. 16" Painted cupola with weathervane
3. Eagle weathervane
4. Rooster weathervane
5. Horse weathervane

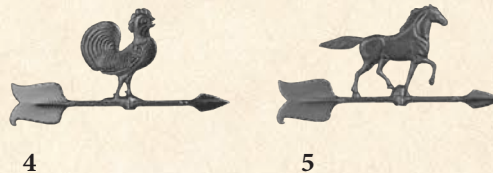

## MISCELLANEOUS OPTIONS

1. Awning roof
2. Post "Y" braces
3. Single or double door threshold
4. Decorative flowerbox holder
5. 12" Decorative hinges *Std. on EZ-Fit Series*

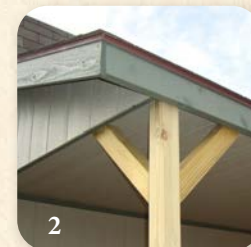



# Built On-Site Structures

- Available in any size building
- Onsite construction eliminates access problems
- Prefabricated panels & trusses are built in our facility
- Optional Painting/Staining  
*Painted by our team before we deliver!*



Built on-site structures are prefabricated in our facility and assembled on the job-site, allowing us to build your shed right on the spot. Painting is optional.



# Prebuilt Structures

- Available in smaller sheds  
*(contact salesman for size limitations)*
- Access needed to site
- Delivered fully assembled
- Includes Painting  
*(with Smartside Siding)*
- Mule Delivery available upon request



Prebuilt structures are assembled in our facility and delivered to your site by truck and trailer. Painting is included on buildings with smartside siding.



Doors Back



Doors Passenger



Mule delivery





# Alpine STRUCTURES

email [sales@alpinestructures.net](mailto:sales@alpinestructures.net)  
phone 330.359.5708 • 800.359.7522

## custom structures

custom built structures – modified to fulfill your expectations.



2675 US 62 · Dundee, Ohio 44624 | Located 1.5 miles West of Winesburg, Ohio | Contractor #PA039333, WV050269 | ©2022

